

Declarations
BK-758 Pg 633

Book 35 page 31

COMMON GROUND HOUSING ASSOCIATES, INC.
ASPEN, PITKIN COUNTY COLORADO

Receipt # 373256
8/15/94

CONDOMINIUM MAP
OF

COMMON GROUND HOUSING SUBDIVISION AT INDEPENDENCE PLACE

AUGUST, 1994

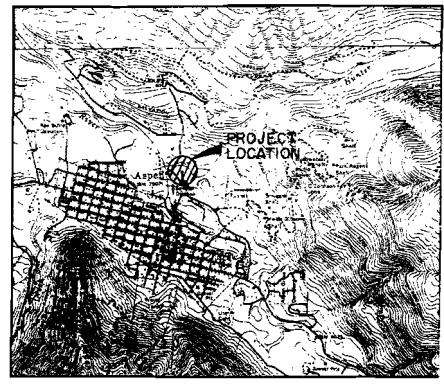

VICINITY MAP

NO.	TITLE
1.	TITLE SHEET
2. - 3.	FINAL PLAT
4. - 9.	BUILDING LAYOUTS

BANNER

BANNER ASSOCIATES, INC. • CONSULTING ENGINEERS & SURVEYORS
2777 CROSSROADS BOULEVARD • GRAND JUNCTION, CO 81506 • (303) 243-2242

JOB NO. 826C-06

William E. Thibault
(Circular stamp)

Aug. 11, 1994

Book 36 pg 34

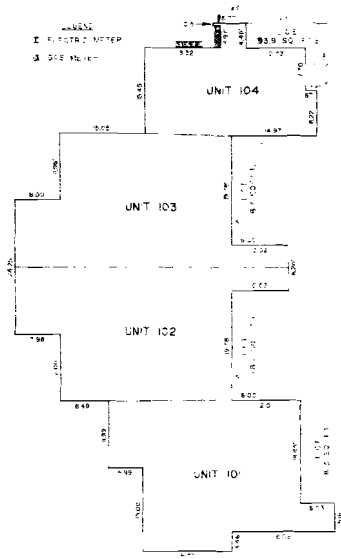

BUILDING ONE (EXTERIOR)

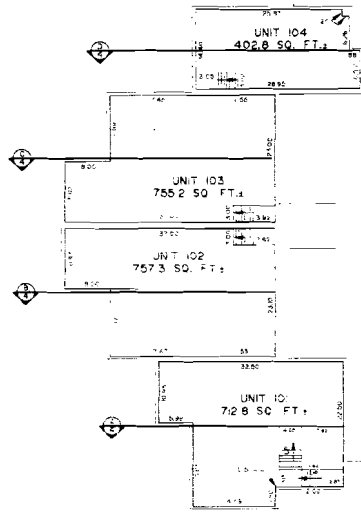

BUILDING ONE (FIRST FLOOR)

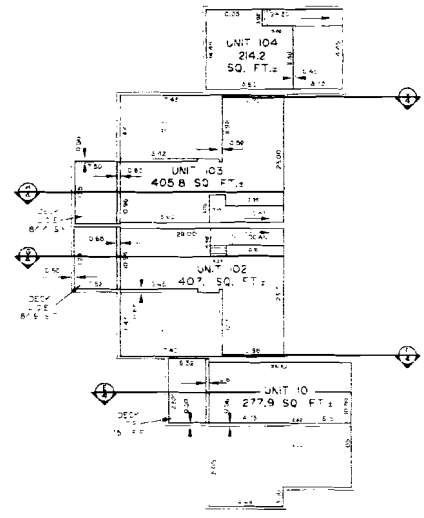

BUILDING ONE (SECOND FLOOR)

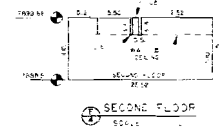

CROSS SECTION - UNIT 101

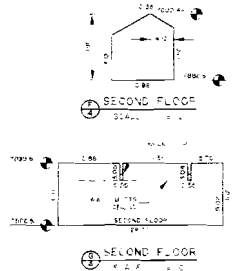

CROSS SECTION - UNIT 102

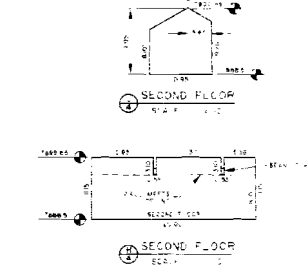

CROSS SECTION - UNIT 103

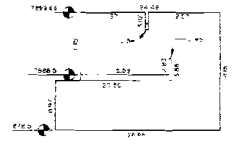

CROSS SECTION - UNIT 104

NOTE:
 1. ALL UNITS SHOWN ARE APPROXIMATE.
 2. ALL UNITS SHOWN ARE APPROXIMATE.
 3. ALL UNITS SHOWN ARE APPROXIMATE.
 4. ALL UNITS SHOWN ARE APPROXIMATE.

Walter J. Walker
 Surveyor
 No. 1000
 State of Colorado
 Exp. 12/31/94

Aug 11, 1994

1001

1001

BANNER

BANNER ASSOCIATES, INC. • CONSTRUCTION ENGINEERS & SURVEYORS
 2777 COPPERHILL DRIVE, SUITE 100 • SPARK JUNCTION, CO. 80066 • (303) 243-2947
 500 E. MAIN • SUITE 9 • ASPEN, CO. 81611 • (303) 925-5867

CONDOMINIUM MAP OF COMMON GROUND HOUSING SUBDIVISION A -
 INDEPENDENCE PLACE, ASPEN, PITKIN COUNTY, COLORADO

Sheet No. 2 of 9
 Date: 8/11/94
 Scale: 1" = 10'

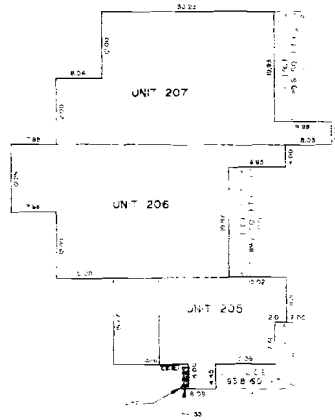

BUILDING TWO (EXTERIOR)

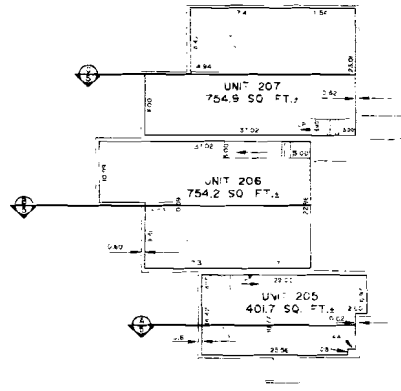

BUILDING TWO (FIRST FLOOR)

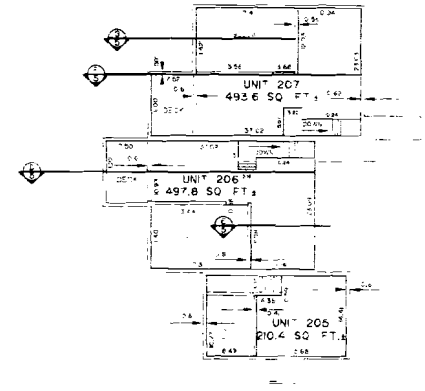

BUILDING TWO (SECOND FLOOR)

LEGEND:
 E ELECTRICAL
 S 245 TO SP



CROSS SECTION - UNIT 205
 SCALE: 1/8" = 1'-0"

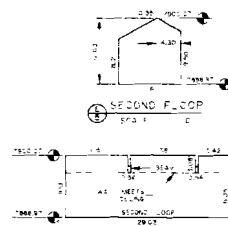

CROSS SECTION - UNIT 206
 SCALE: 1/8" = 1'-0"

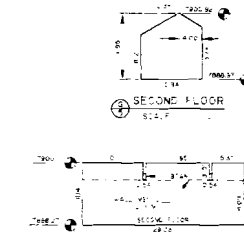

CROSS SECTION - UNIT 207
 SCALE: 1/8" = 1'-0"

NOTE:
 FIRST FLOOR (ENTIRE) AND SECOND FLOOR (AREA 1) ARE TO BE CONSIDERED AS ONE UNIT FOR THE PURPOSES OF THIS MAP.
 ALL WALLS AND PARTITIONS ARE TO BE CONSIDERED AS PART OF THE COMMON ELEMENTS.
 FIRST FLOOR AREA IS TO BE CONSIDERED AS ONE UNIT FOR THE PURPOSES OF THIS MAP.

Walker & Balle
 Surveyors
 1994

Aug 11, 1994

BANNER

BANNER ASSOCIATES, INC. • CONSULTING ENGINEERS & SURVEYORS
 2777 CROSSROADS BOULEVARD • DENVER, COLORADO 80202 • (303) 443-2247
 920 F. MAIN ST. SUITE 4 • ASPEN, CO 81602 • (303) 926-2807

CONDOMINIUM MAP OF COMMON GROUND HOUSING SUBDIVISION AT
 INDEPENDENCE PLACE ASPEN, PITKIN COUNTY, COLORADO

SCALE: 1/8" = 1'-0" DATE: 8/26/94
 SHEET: 5 OF 9

1000
 1000

SECTION

SECTION

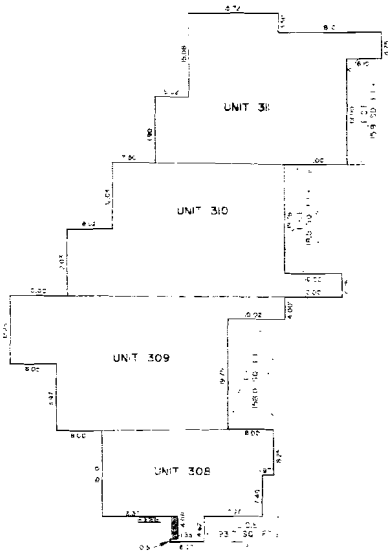

BUILDING THREE (EXTERIOR)

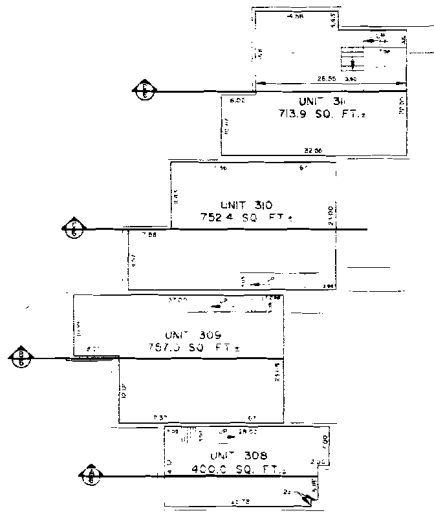

BUILDING THREE (FIRST FLOOR)

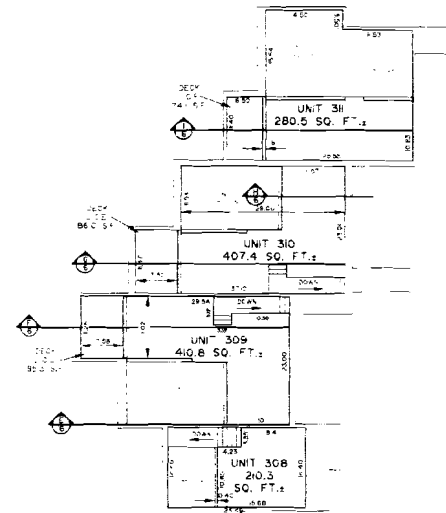

BUILDING THREE (SECOND FLOOR)

NOTE:
FIRST FLOOR AREAS INCLUDE AREAS
COMPLY TO AREA'S WHILE SECOND FLOOR
AREAS EXCLUDE OPEN TO SKY DECKS
STAIRCASE HEADS ARE INCLUDED IN
FIRST FLOOR AREAS BUT EXCLUDED
FROM SECOND FLOOR TREATMENT

LEGEND
 CUSTOM METAL
 DOOR MARKER

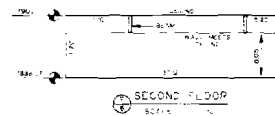

SECOND FLOOR
SCALE: 1/4" = 1'-0"

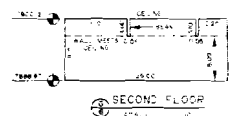

SECOND FLOOR
SCALE: 1/4" = 1'-0"

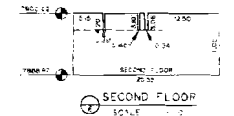

SECOND FLOOR
SCALE: 1/4" = 1'-0"

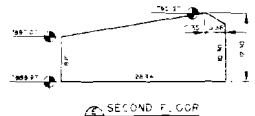

SECOND FLOOR
SCALE: 1/4" = 1'-0"



SECOND FLOOR
SCALE: 1/4" = 1'-0"

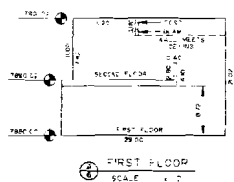

FIRST FLOOR
SCALE: 1/4" = 1'-0"

CROSS SECTION - UNIT 308

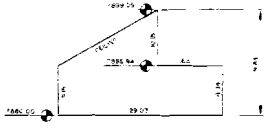

FIRST FLOOR
SCALE: 1/4" = 1'-0"

CROSS SECTION - UNIT 309

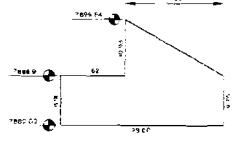

FIRST FLOOR
SCALE: 1/4" = 1'-0"

CROSS SECTION - UNIT 310

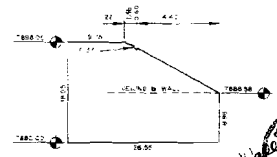

FIRST FLOOR
SCALE: 1/4" = 1'-0"

CROSS SECTION - UNIT 311

Walter J. ...
 REGISTERED
 SURVEYOR
 No. 1111
 STATE OF COLORADO
 August 11, 1994

BANNER

BANNER ASSOCIATES, INC. • CONSULTING ENGINEERS & SURVEYORS
 2777 CROSSROADS BLVD. • GRAND JUNCTION, CO 81505 • (970) 243-1241
 600 E. MAIN • SUITE B • ASPEN, CO 81611 • (970) 925-5807

CONDOMINIUM MAP OF COMMON GROUND HOUSING SUBDIVISION AT
 INDEPENDENCE PLACE, ASPEN, PITKIN COUNTY, COLORADO

SCALE: 1" = 10' JOB NO: 8260.06 DATE: 8-10-94
 SHEET NO: 6 OF 9

P637

BK35

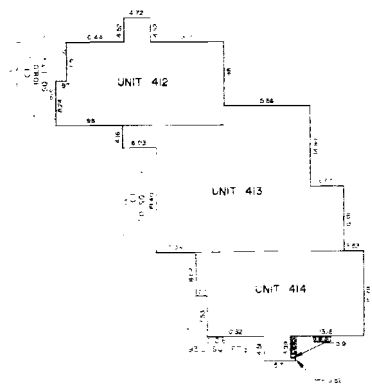

BUILDING FOUR (EXTERIOR)

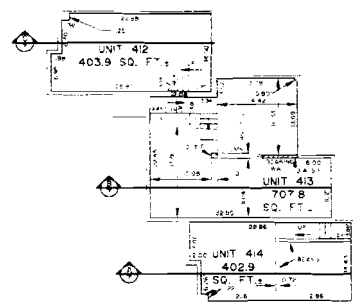

BUILDING FOUR (FIRST FLOOR)

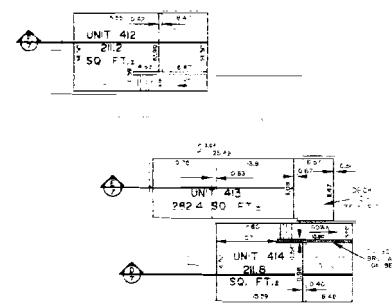

BUILDING FOUR (SECOND FLOOR)

LEGEND
 E ELECTRIC METERS
 M GAS METERS

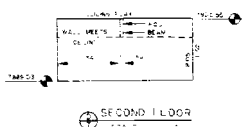

CROSS SECTION - UNIT 414

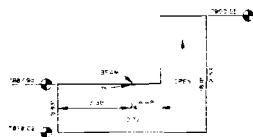

CROSS SECTION - UNIT 413

CROSS SECTION - UNIT 414

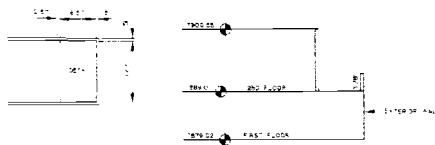

SECOND FLOOR DECK

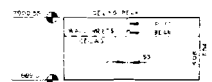

CROSS SECTION - UNIT 414

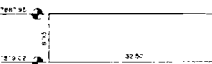

CROSS SECTION - UNIT 413

CROSS SECTION - UNIT 413

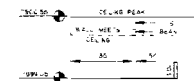

CROSS SECTION - UNIT 412

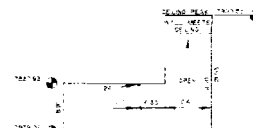

CROSS SECTION - UNIT 414

CROSS SECTION - UNIT 412

NOTE:
 FIRST FLOOR APARTS VOLUME AREAS
 OPEN TO SECOND FLOOR SECOND FLOOR
 APARTS VOLUME AREAS ARE BELOW AREAS
 SHOWN AREAS ARE INCLUDED IN
 FIRST FLOOR VOLUME AREAS EXCEPT
 FROM SECOND FLOOR AREAS

Walter B. ...
 Aug 11, 1994

BANNER

BANNER ASSOCIATES, INC. • CONSULTING ENGINEERS & SURVEYORS
 2777 INDEPENDENCE BOULEVARD • BRAND LANTON, CO. 80604 • (303) 443-2242
 402 E. MAIN • SUITE 110 • ASPEN, CO. 81611 • (303) 926-0067

CONDOMINIUM MAP OF COMMON GROUND HOUSING SUBDIVISION AT
 INDEPENDENCE PLACE, ASPEN, PITKIN COUNTY, COLORADO

SCALE 1/8" = 1'-0"
 SHEET NO. 7 of 9

Book 35 pg. 38

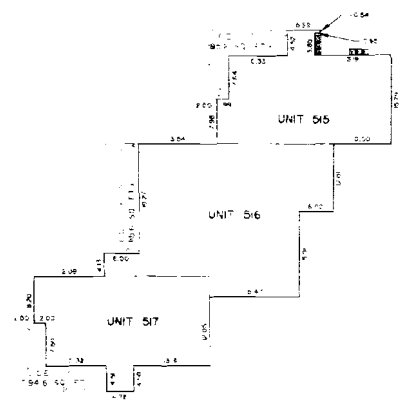

BUILDING FIVE (EXTERIOR)

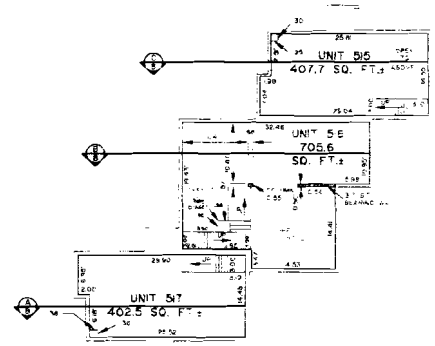

BUILDING FIVE (FIRST FLOOR)

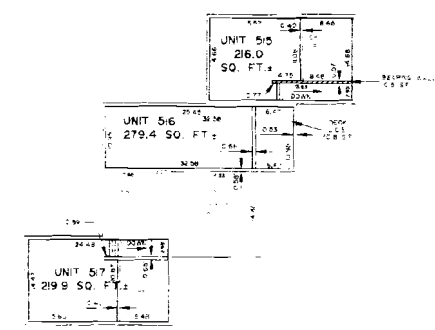

BUILDING FIVE (SECOND FLOOR)

LEGEND
 E ELEVATION
 S SIZES METERS

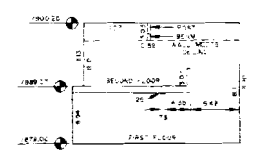

FIRST FLOOR
 SCALE 1/4" = 1'-0"
 CROSS SECTION - UNIT 517

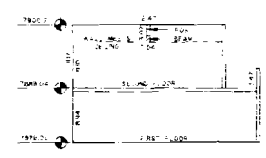

FIRST FLOOR
 SCALE 1/4" = 1'-0"
 CROSS SECTION - UNIT 516

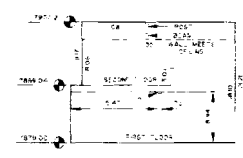

FIRST FLOOR
 SCALE 1/4" = 1'-0"
 CROSS SECTION - UNIT 515

NOTE
 THIS IS NOT A SECTION OF THE APARTMENTS
 OPEN TO THE PUBLIC AND SHOULD NOT
 BE USED FOR ANY OTHER PURPOSE
 WITHOUT THE WRITTEN PERMISSION OF
 THE ARCHITECT

Walter J. ...
 Aug 11, 1994

BANNER
 BANNER ASSOCIATES INC. • CONSULTING ENGINEERS & SURVEYORS
 2717 CROSSROADS BOULEVARD • SPRING JUNCTION, CO. 80068 • (303) 243-2242
 600 E. MAIN • SUITE 6 • ASPEN, CO. 81611 • (303) 925-9887

CONDOMINIUM MAP OF COMMON GROUND HOUSING SUBDIVISION AT
 INDEPENDENCE PLACE, ASPEN, P. TKIN COUNTY, COLORADO

SCALE 1" = 10'
 SHEET NO. 8 of 9

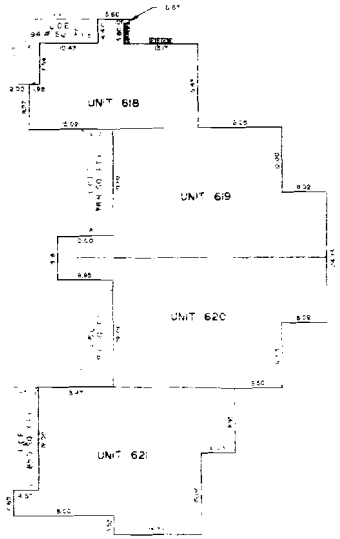

BUILDING SIX (EXTERIOR)

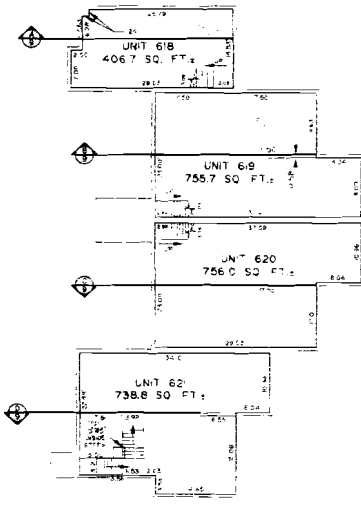

BUILDING SIX (FIRST FLOOR)

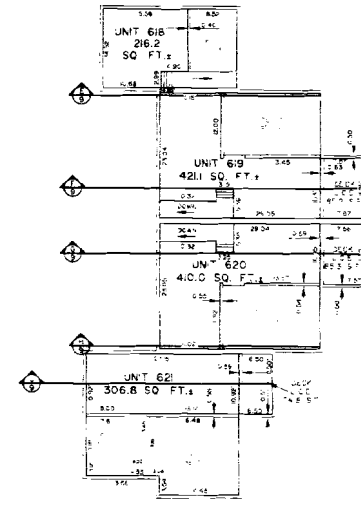

BUILDING SIX (SECOND FLOOR)

UNIT
PARTS OF COMMON AREAS INCLUDE AREAS
OPEN TO AIR OR TO BE OPEN TO AIR
AREAS INCLUDE OPEN TO AIR AREAS
INCLUDE AREAS ARE INCLUDED A
PARTS OF COMMON AREAS ARE INCLUDED
FROM SECOND FLOOR UPWARDS

UNITS
I 2.00 METERS
II 1.00 METERS

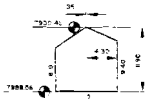

CROSS SECTION - UNIT 618

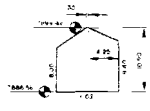

CROSS SECTION - UNIT 619

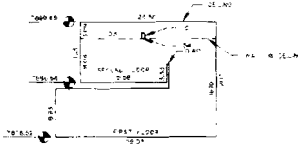

FIRST FLOOR
SCALE 1/8" = 1'-0"

CROSS SECTION - UNIT 618

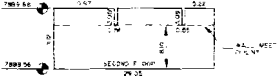

SECOND FLOOR
SCALE 1/8" = 1'-0"

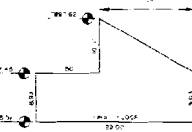

FIRST FLOOR
SCALE 1/8" = 1'-0"

CROSS SECTION - UNIT 619

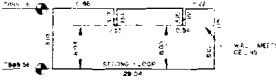

SECOND FLOOR
SCALE 1/8" = 1'-0"

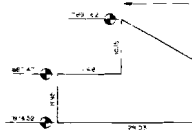

FIRST FLOOR
SCALE 1/8" = 1'-0"

CROSS SECTION - UNIT 620



SECOND FLOOR
SCALE 1/8" = 1'-0"

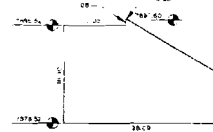

FIRST FLOOR
SCALE 1/8" = 1'-0"

CROSS SECTION - UNIT 621



Aug 11, 1994

BANNER
BANNER ASSOCIATES, INC. • CONSULTING ENGINEERS & SURVEYORS
2777 UNDERWOOD BOULEVARD • DENVER, COLORADO 80202 • PHONE 343-2242
BOX C, WARD • SUITE 10 • ASPEN, CO 81611 • (303) 926-1007

CONDOMINIUM MAP OF COMMON GROUND HOUSING SUBDIVISION AT
INDEPENDENCE PLACE, ASPEN, PITKIN COUNTY, COLORADO

SHEET NO 9 of 9